

SE8600 Series Installation Guide

Rooftop Unit, Heat Pump and Indoor Air Quality Controller



CONTENTS

Installation	2
Terminal Identification & Function	3
Terminal identification	3
Typical Applications	4
2H / 2C	5
2C / Mod. heat	6
2C / Aux. Eco	6
Remote Sensor Accessories	7
Home Screen Display	8
How to Enter Setup Screen	9
Appendixes	10
Support	11

INSTALLATION

Location

- Do not install on outside wall.
- Do not install in areas with direct heat source.
- Do not install near any air discharge grill.
- Do not install in areas exposed to direct sunlight.
- Ensure Room Controller has sufficient air circulation.
- Ensure wall surface is flat and clean.

Installation

1. Remove security screw (if any) on bottom of Room Controller cover.
2. Open unit by pulling on bottom side of Room Controller (Figure 1).
3. Read FCC ID and IC label installed in cover before installing any wireless product.
4. Ensure correct side of base faces up.
5. Pull cables 6in (15cm) out from wall.
6. Align base and mark location of two mounting holes on wall (Figure 2).
7. Install anchors in wall.
8. Insert cable in central hole of base.
9. Insert screws in mounting holes on each side of base.
10. Strip each wire 1/4in (0.6cm) from end.
11. Insert each wire and screw according to wiring chart.
12. Gently push excess wiring back into hole.
13. Gently align cover to top of base and snap in place from bottom (Figure 3).
14. Install security screw.

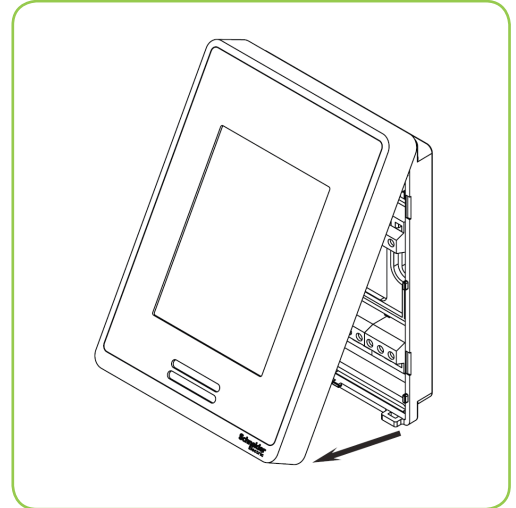

Figure-1 Open cover

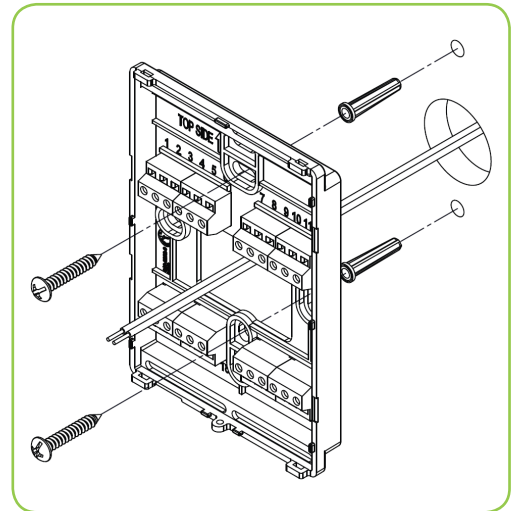

Figure-2 Install base



- If replacing an existing device, label wires before removal of Room Controller.
- Electronic controls are static sensitive devices. Discharge yourself correctly before manipulating and installing Room Controller.
- A short circuit or wrong wiring may permanently damage Room Controller or equipment.
- All SE8600 series controls are designed for use as operating controls only and are not safety devices. Tampering with the devices or unintended application of the devices will result in a void of warranty.
- This device must be installed to provide a separation distance of at least 8in (20cm) from all persons and must not be located or operating in conjunction with any other antenna or transmitter.

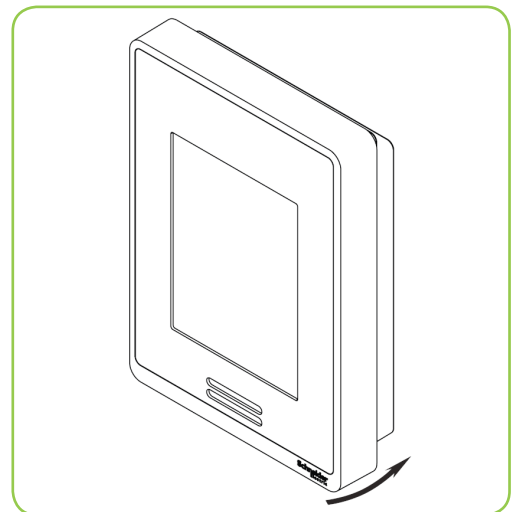

Figure-3 Reinstall cover

TERMINAL IDENTIFICATION AND FUNCTION

Terminal identification

SE86xxU Description / Application	Used in applications
	IAQ, HP & RTU
Internal Temperature	X
1- BO1	Aux
2- BO2	Y2
3- BO3	Y1
4- BO4	G
5- RC	RC (24 Vac)
6- C	Common
7- RH	RH
8- BO8	W1
9- UO9	W2 / OB
10- UO10	Econo (0-10 Vdc)
11- UO11	Heat (0-10 Vdc), set "Heat Stages" to 0 to enable
12- UO12	Dehumidification output (24 Vac On/Off)
13- RS485 +	BACnet (+)
14- RS485 -	BACnet (-)
15- RS485 Ref	BACnet Ref. (do not sire shield in this terminal)
16- UI16	UI16 (multifunction input)
17- UI17	UI17 (multifunction input)
18 Scom	Common
19- UI19	CO2 (0-10 Vdc input)
20- UI20	RS (Remote sensor input 10K, type 2 thermistor)
21 Scom	Common
22- UI22	SS (Supply sensor input 10K, type 2 thermistor)
23- UI23	OS (Outside sensor input 10K, type 2 thermistor)
24- UI24	Airflow (0-10 Vdc input)

TYPICAL APPLICATIONS

SE8600 RTU: 2 Heating / 2 Cooling

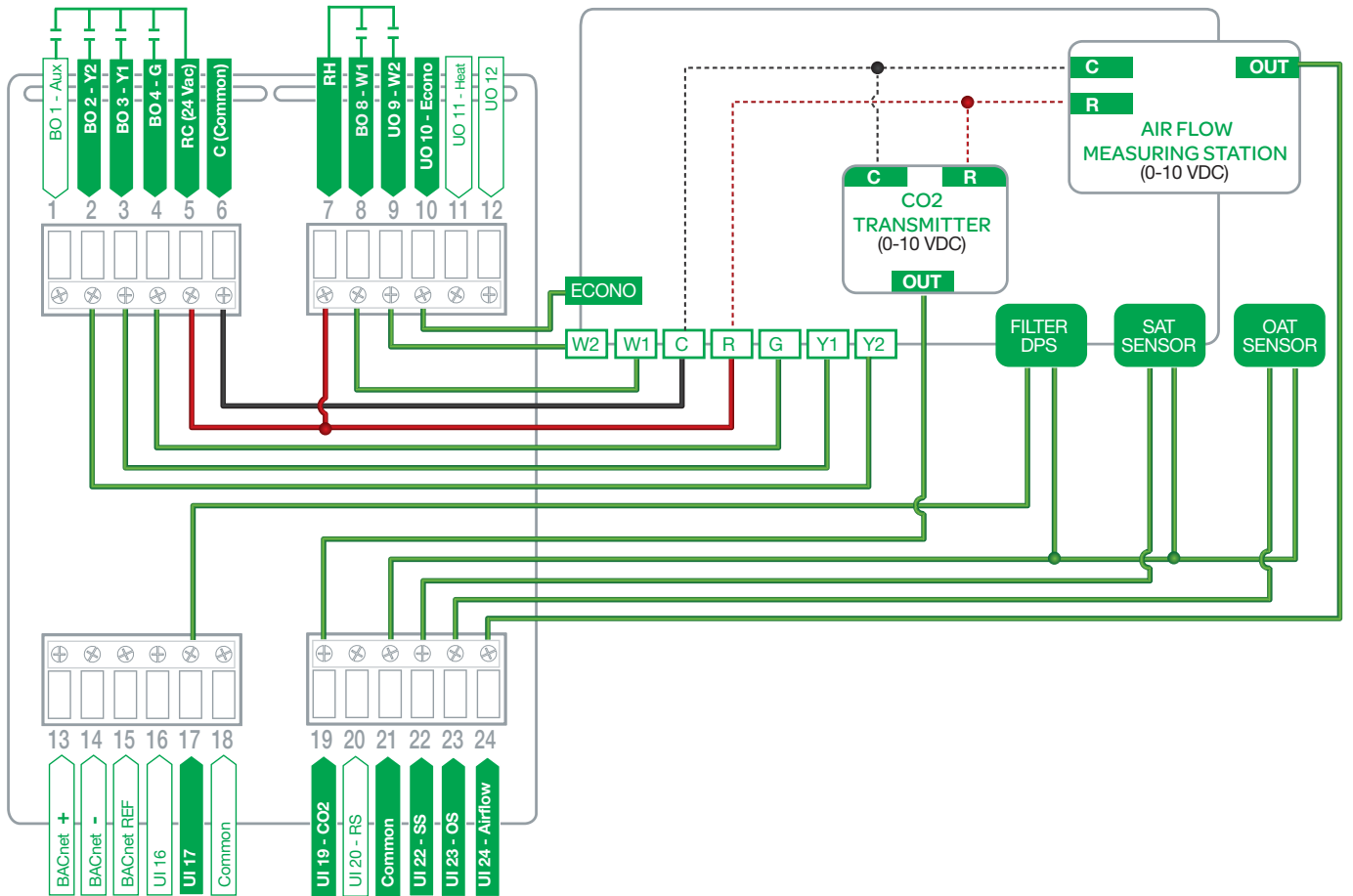

SE8600 RTU: 2 Cooling / Modulating Heat

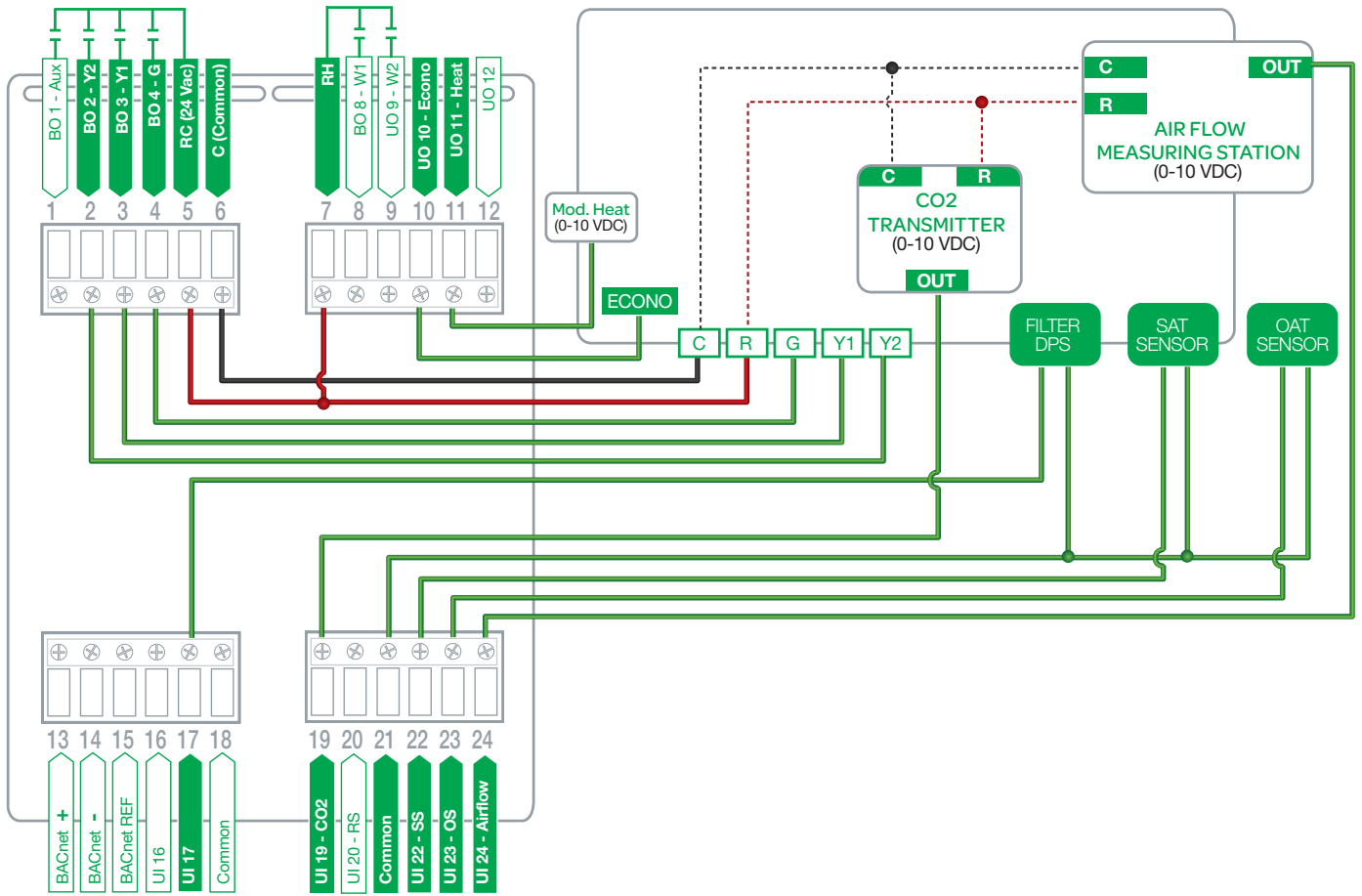

SE8600 HPU: 2 Compressors, Auxiliary Heat and Economizer

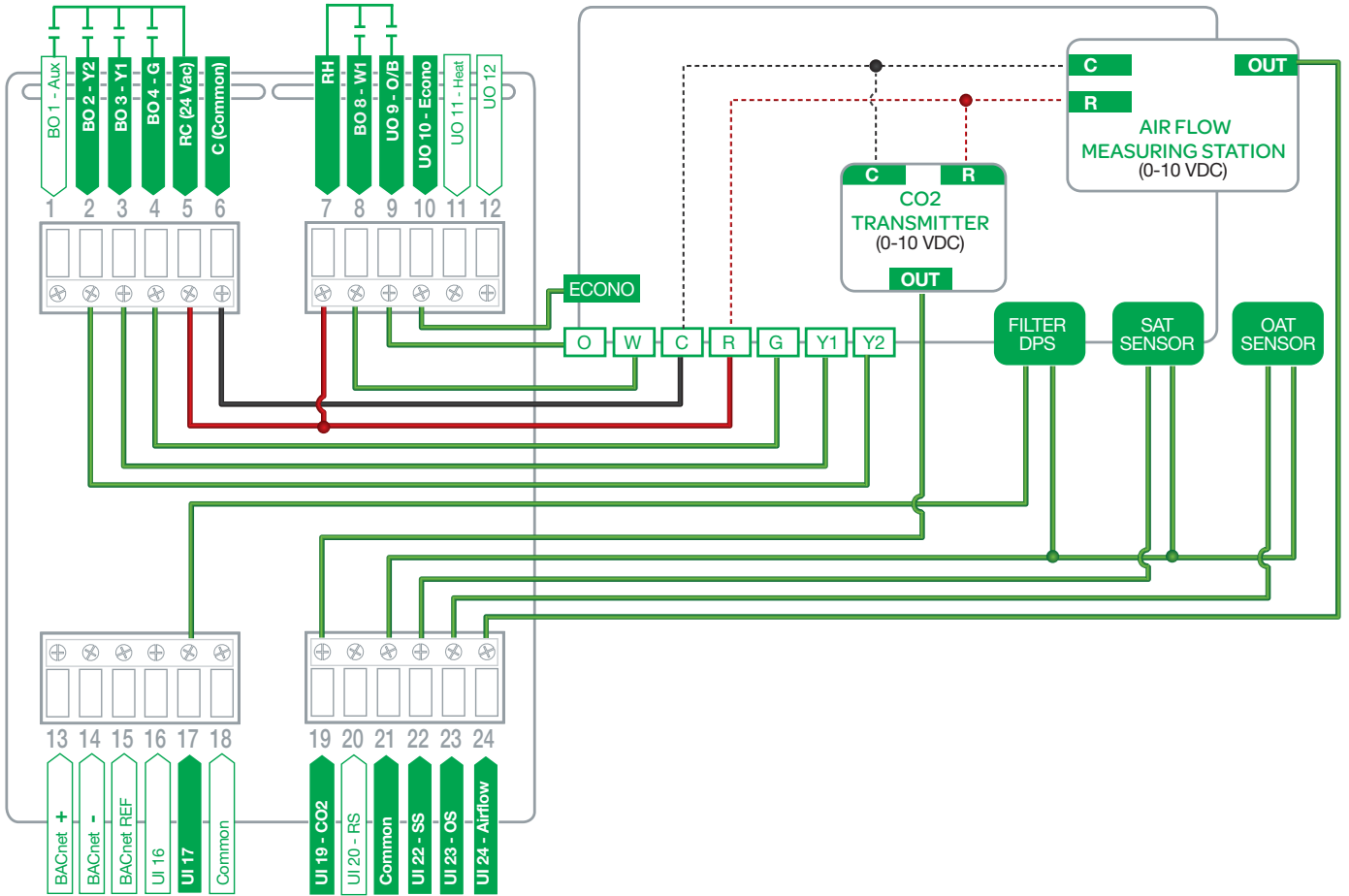

REMOTE SENSOR ACCESSORIES

Model no.	Description
S3010W1045	Wall mounted temperature sensor
S3020W1045	Wall mounted temperature sensor with override button and occupancy status LED

Note:

If one or multiple sensor(s) is/are connected into the RS terminal, the internal temperature sensor is automatically disabled. Disconnecting the sensor(s) in RS terminal will re-activate the internal sensor.

Remote mount temperature sensors inputs use 10K type 2 NTC thermistors.

Features:

- Each sensor can be configured for various averaging combinations. Refer to S3000 series remote sensors for more details.

Temperature vs. resistance chart for 10 Kohm NTC thermistor (R25°C = 10KΩ±3%, B25/85°C = 3975K±1.5%)

°C	°F	Kohm	°C	°F	Kohm	°C	°F	Kohm	°C	°F	Kohm	°C	°F	Kohm
-40	-40	324.3197	-20	-4	94.5149	0	32	32.1910	20	68	12.4601	40	104	5.3467
-35	-31	234.4009	-15	5	71.2430	5	41	25.1119	25	77	10.0000	45	113	4.3881
-30	-22	171.3474	-10	14	54.1988	10	50	19.7390	30	86	8.0694	50	122	3.6202
-25	-13	126.6109	-5	23	41.5956	15	59	15.6286	35	95	6.5499	55	131	3.0016

HOME SCREEN DISPLAY

Typical Hospitality User Interface Shown

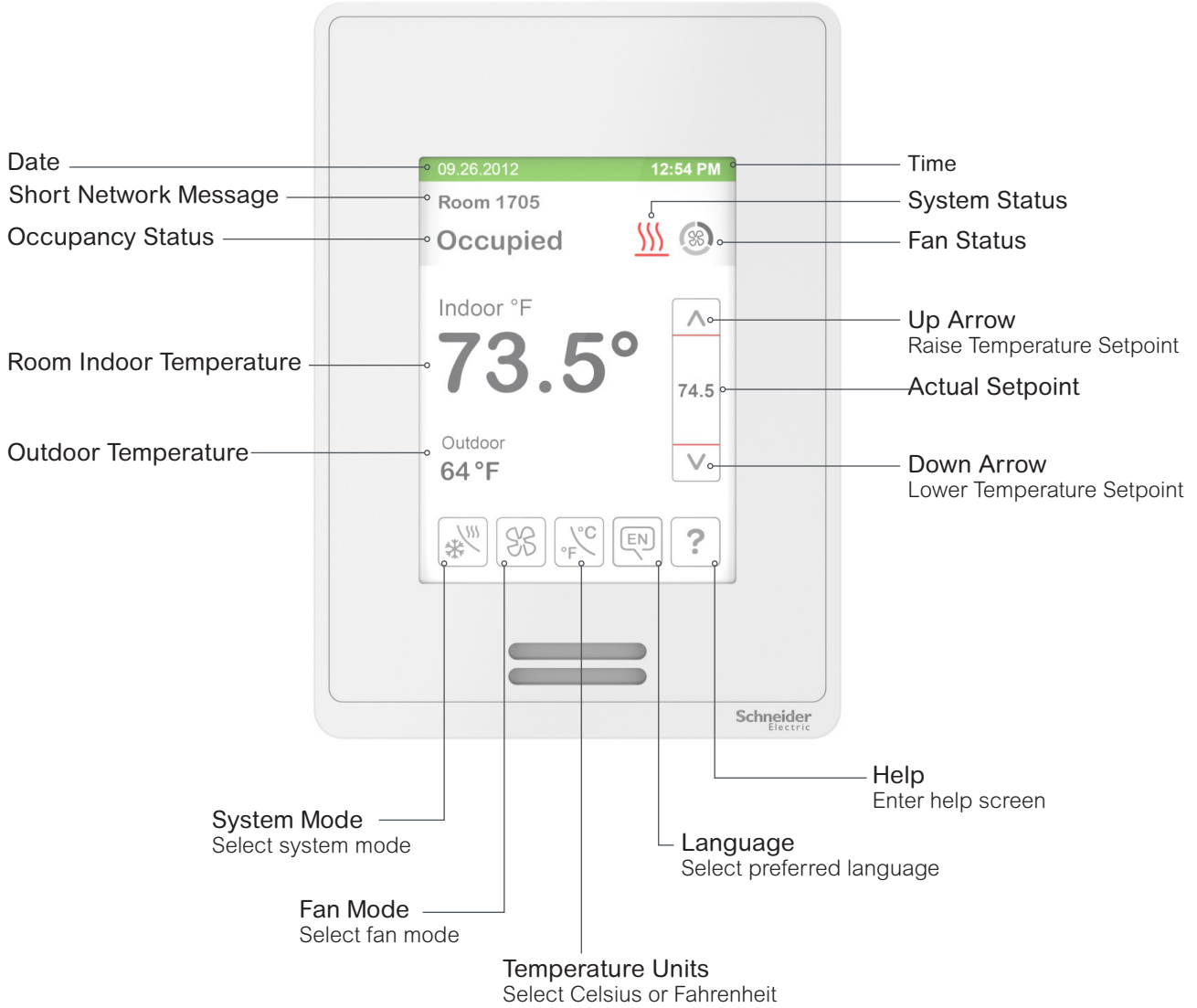

Note: User HMI is configurable and allows display functions such as Outdoor Temperature, Setpoint, and other buttons to be enabled or disabled by setting various parameters in the setup screens.

HOW TO ENTER SET-UP SCREEN

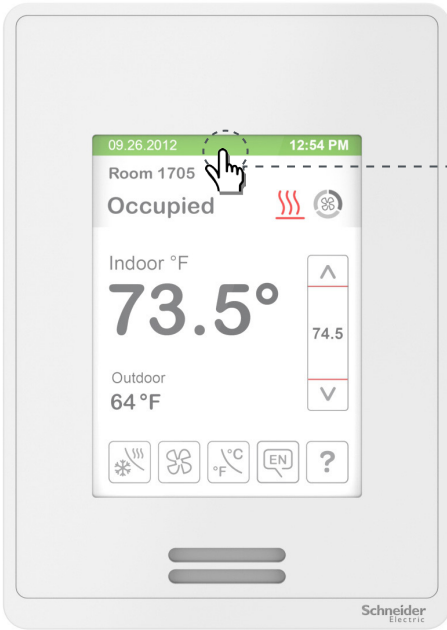

Touch and hold this point for 3 seconds to enter set-up mode

Note: If a configuration/installer password is activated to prevent unauthorised access to the configuration menu parameters, a password entry prompt shows to prevent access to device configuration components.

For more information on using and configuring the functions of the HMI, refer to **SE8600 User Interface Guide**

SET-UP SCREEN DISPLAY

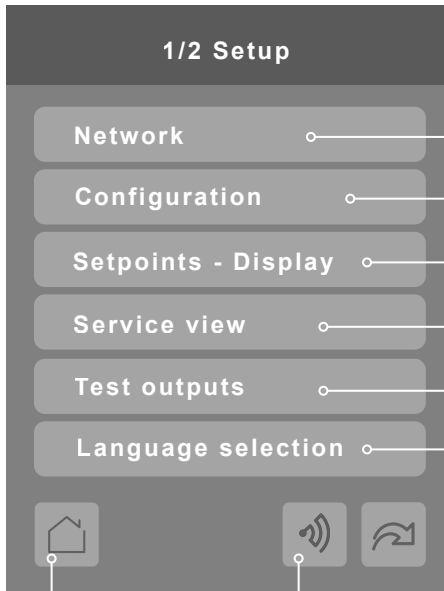

Enter BACnet® & ZigBee® network settings

Enter parameter configuration menu

Enter setpoint & display settings

Enter status and service view

Enter output testing mode

Enter language selection

Return to home screen

Discover Mode The Controller becomes discoverable on the wireless ZigBee® network for 1 minute (this button is hidden if ZigBee® settings are not configured)

General Note:

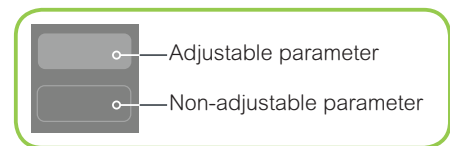

APPENDIX A TERMINAL CORRESPONDENCE

The terminals of a SE8600 are identified differently and have a wider range of possible functions compared to those of any of the SE7000 series Room Controllers. Nonetheless, there is a direct correspondence of functions between the terminals of the SE7000 series and the SE8600 series. Consult the table below to verify the appropriate terminal when replacing a SE7000 Room Controller with a SE8600 Room Controller.

SE7000		SE8600	
Terminal name	Terminal ID	Terminal name	Terminal ID
Binary Input 1	BI1	Universal Input 16	UI16
Binary Input 2	BI2	Universal Input 17	UI17
Universal Input 3	UI3	Universal Input 19	UI19
Sensor Common	Scom	Terminal 18 Common	COM
Remote Sensor	RS	Universal Input 20	UI20 - RS
Sensor Common	Scom	Terminal 21 Common	COM
Mix/Supply Sensor	MS	Universal Input 22	UI22 - SS

APPENDIX B POWER OUTAGE CLOCK RESET

In the event of a power outage, SE8600 Room Controllers retain the correct time as long as the duration of the power outage is not prolonged. Depending on the duration of the power outage, the Room Controllers internal clock may need to be updated or reset completely. The following table gives an indication of the expected clock performance after a power outage of a given duration.

Outage duration	Room Controller behavior
0 - 24 hours	Clock functions are normal
24 - 36 hours	Clock accuracy not guaranteed, time may need to be adjusted
36 - 72 hours	Clock no longer increments and must be adjusted when power is restored.
72+ hours	Clock functions are fully reset, and must be reinitialized as per a new installation.

Schneider Electric is the global specialist in energy management and automation. With revenues of 25 billion in FY2014, our 170,000 employees serve customers in over 100 countries, helping them to manage their energy and process in ways that are safe, reliable, efficient and sustainable. From the simplest of switches to complex operational systems, our technology, software and services improve the way our customers manage and automate their operations. Our connected technologies will reshape industries, transform cities and enrich lives.

At Schneider Electric, we call this **Life Is On.**